

POSEIDON FIT



Waste Water Treatment

POSEIDON FIT

5ppm Bilge Oil Water Separator
according to all Environmental Class Notations



EPE / Environmental Protection Engineering S.A.

OPERATION

POSEIDON FIT Bilge Oil Water Separator consists of two stages; the coalescer and the emulsion breaking unit. The coalescer works on a continuous mode, by-passing the second stage. If the detection monitor senses content higher than 4ppm at the effluent of the coalescer oil, then the emulsion breaking unit begins its operation. Due to an effective hydrocarbon absorption material the effluent of 5ppm or less, is ensured, according to the new Environmental Class Notations. In that way, the operation and maintenance cost is minimized and the life of the equipment is prolonged.

BENEFITS

- ✓ Fully Automatic Unattended Operation
 - ✓ Self-cleaning through Backwash
 - ✓ By-passing Mode of the Electrolytic Stage for Prolonged Operation
 - ✓ Pressure Type that Fits All New-Building Designs
 - ✓ Military Applications Version Available
 - ✓ Minimum Maintenance
 - ✓ No Chemicals
 - ✓ Plug-N-Play Installation
 - ✓ Reliable Operation
 - ✓ Minimum Volume & Footprint
- ✓ IMO RES. MEPC. 107 (49) Approved

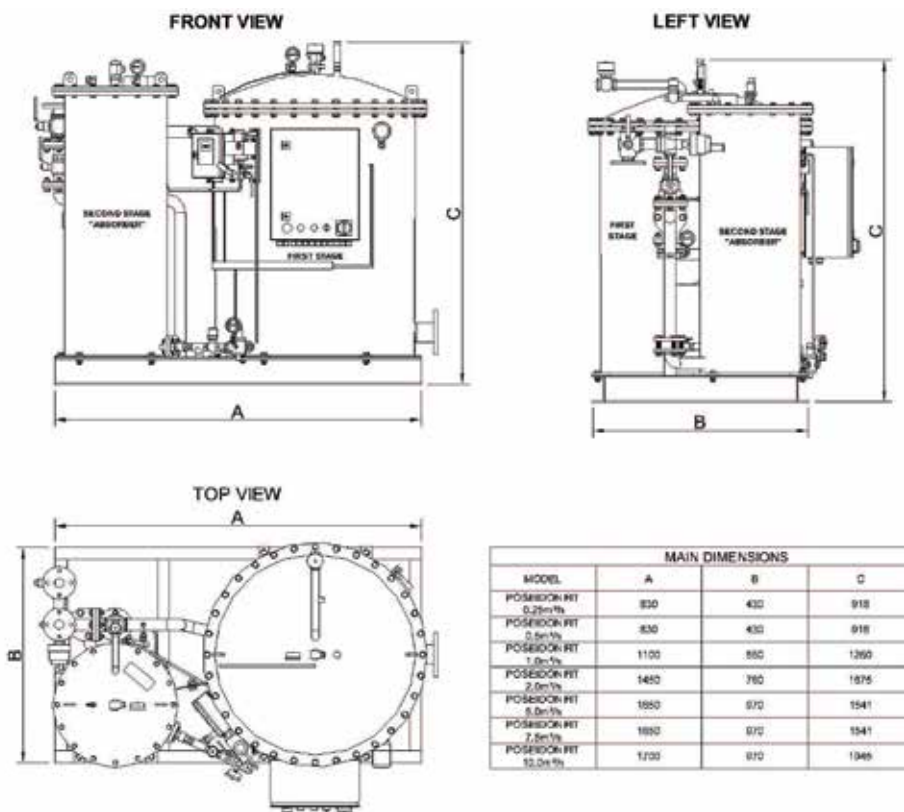

EPE / Environmental Protection Engineering S.A.



HEAD OFFICES

Piraeus, Greece

T: +30 210 40 60 000

F: +30 210 46 17 423

FACTORY

VIPAS, Perama, Greece

T: +30 210 40 93 000

F: +30 210 46 17 423

• website: www.epe.gr

• email: epe@epe.gr

OPERATION

POSEIDON FIT Bilge Oil Water Separator consists of two stages; the coalescer and the emulsion breaking unit. The coalescer works on a continuous mode, by-passing the second stage. If the detection monitor senses content higher than 4ppm at the effluent of the coalescer oil, then the emulsion breaking unit begins its operation. Due to an effective hydrocarbon absorption material the effluent of 5ppm or less, is ensured, according to the new Environmental Class Notations. In that way, the operation and maintenance cost is minimized and the life of the equipment is prolonged.

BENEFITS

- ✓ Fully Automatic Unattended Operation
 - ✓ Self-cleaning through Backwash
 - ✓ By-passing Mode of the Electrolytic Stage for Prolonged Operation
 - ✓ Pressure Type that Fits All New-Building Designs
 - ✓ Military Applications Version Available
 - ✓ Minimum Maintenance
 - ✓ No Chemicals
 - ✓ Plug-N-Play Installation
 - ✓ Reliable Operation
 - ✓ Minimum Volume & Footprint
- ✓ IMO RES. MEPC. 107 (49) Approved

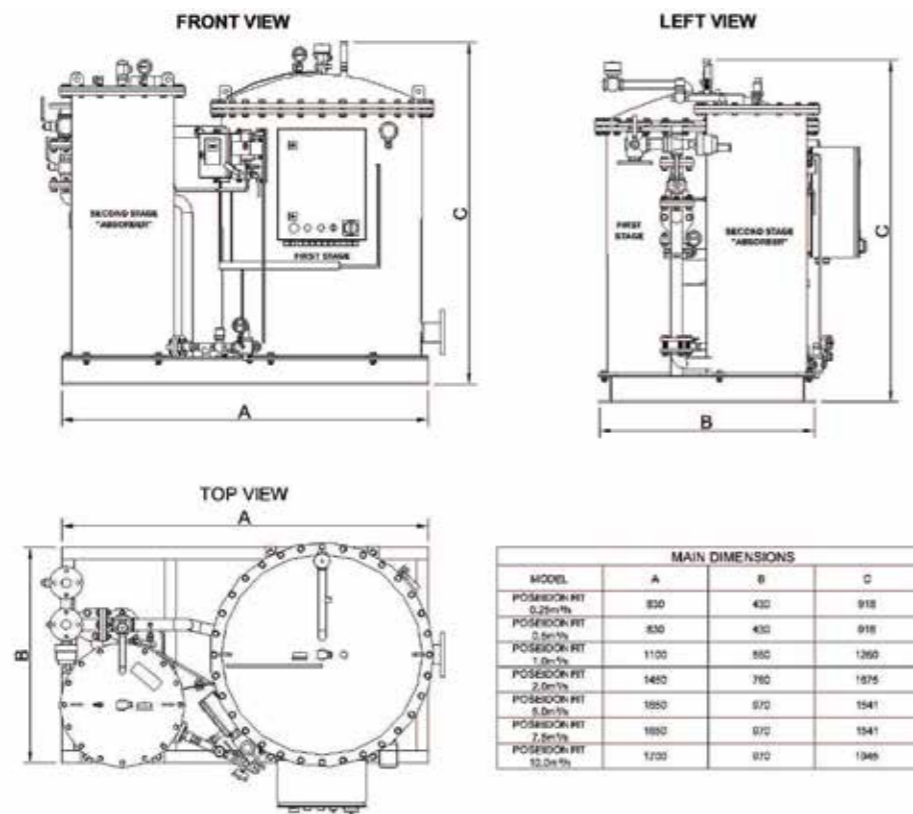

POSEIDON FIT



Waste Water Treatment

POSEIDON FIT
5ppm Bilge Oil Water Separator
according to all Environmental Class Notations



EPE / Environmental Protection Engineering S.A.



HEAD OFFICES
Piraeus, Greece
T: +30 210 40 60 000
F: +30 210 46 17 423

FACTORY
VIPAS, Perama, Greece
T: +30 210 40 93 000
F: +30 210 46 17 423

- website: www.epe.gr
- email: epe@epe.gr

EPE / Environmental Protection Engineering S.A.